



First in Quality, First in Service.

---

# HVAC PRODUCTS

---

VOLUME 6

---

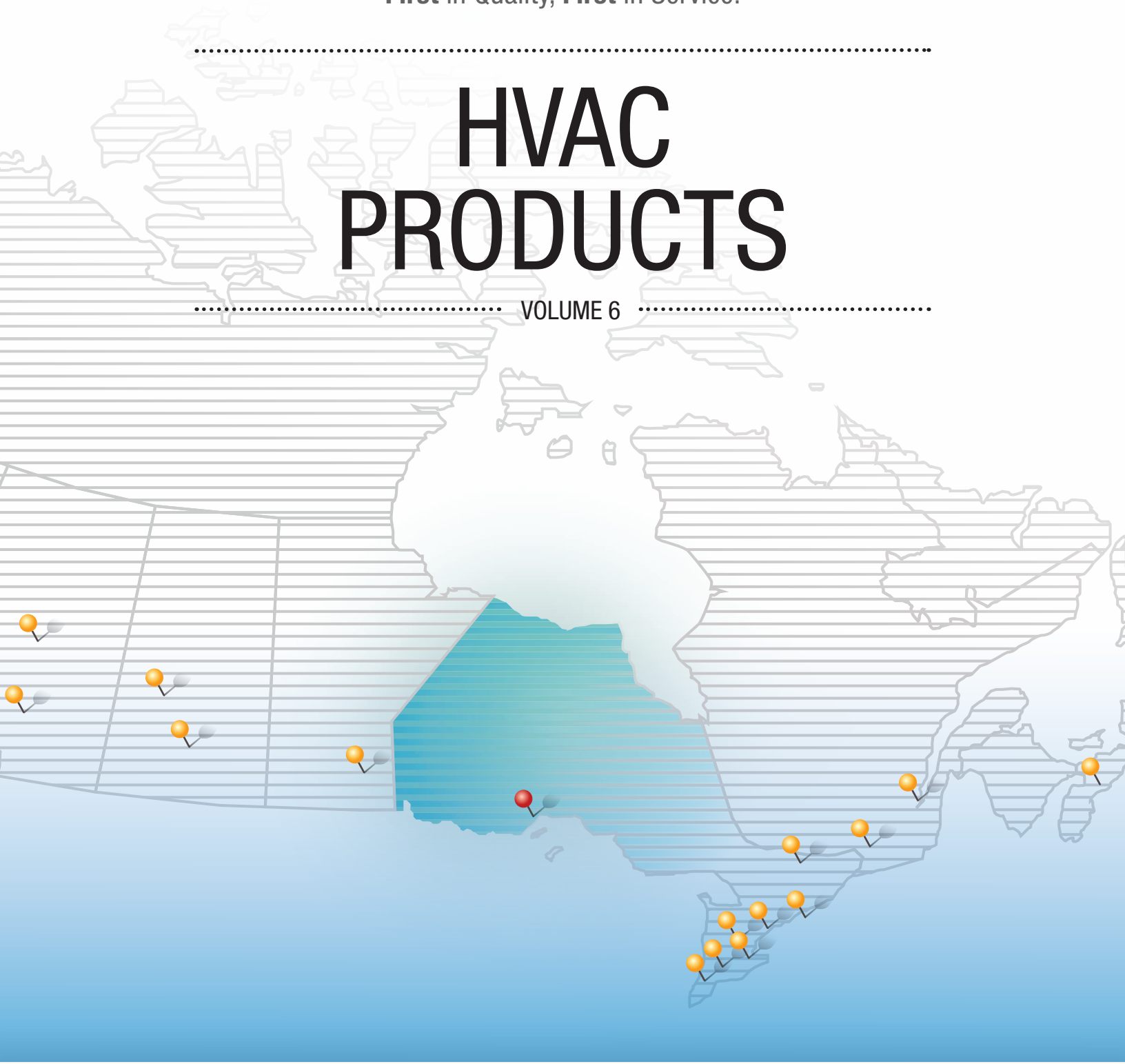

**THUNDER BAY**

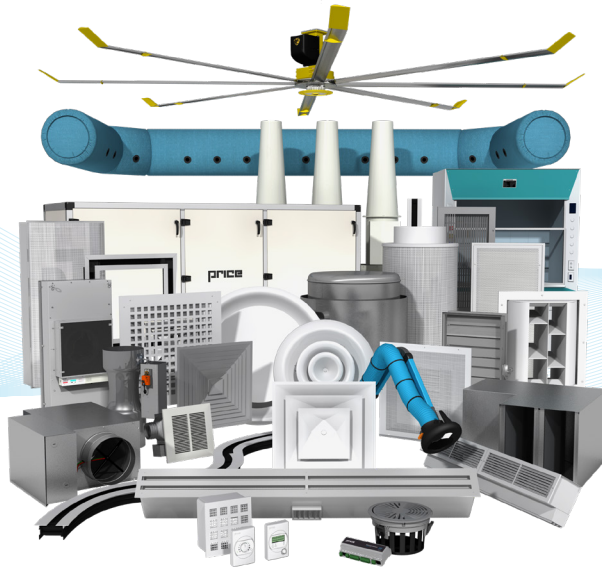

# ..... AIR DISTRIBUTION PRODUCTS .....

## GRILLES, REGISTERS & DIFFUSERS

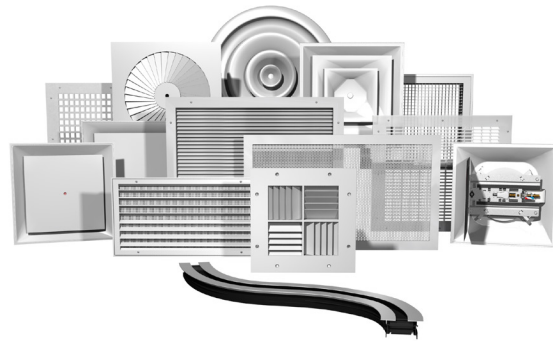

**price** | GRILLES

Price Industries Limited  
[www.priceindustries.com](http://www.priceindustries.com)

**price** | DIFFUSERS

Price Industries Limited  
[www.priceindustries.com](http://www.priceindustries.com)

### Grilles & Registers

- Standard Grilles and Registers
- Linear Bar Grilles
- Airfoil Series Grilles and Registers
- Industrial / Special Application
- Filter Grilles
- Condo Grilles
- Nozzles
- Security Products
- Heavy Duty Gym Grilles

### Linear Diffusers

- Custom Flow Linear Diffusers
- Linear Slot Diffusers

### Ceiling Component Diffusers

- T-Bar Diffusers
- Light Troffer Diffusers
- Low Temperature Diffusers

### Ceiling Diffusers

- Square Ceiling Diffusers
- Perforated Ceiling Diffusers
- Square and Rectangular Directional Diffusers
- Round Cone Diffusers
- VAV Diffusers

## UNDERFLOOR AIR DISTRIBUTION

---

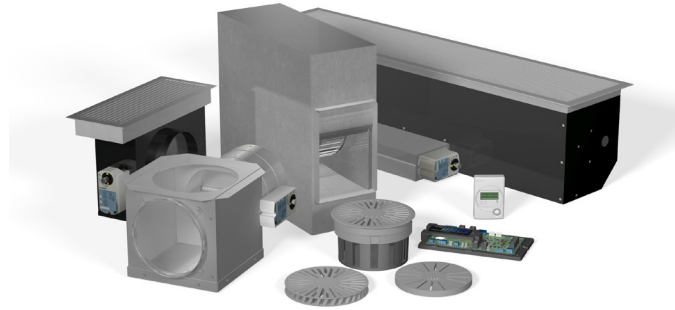

**price** | UNDERFLOOR

**Price Industries Limited**  
[www.priceindustries.com](http://www.priceindustries.com)

### Underfloor Air Distribution

- Round Floor Diffusers
- Linear Floor Grilles
- Linear Floor Heaters
- Underfloor Controllers
- Underfloor Terminal Units
- Underfloor Deflection Grilles

## DISPLACEMENT VENTILATION

---



**price** | DIFFUSERS

**Price Industries Limited**  
[www.priceindustries.com](http://www.priceindustries.com)

### Displacement Ventilation

- Wall Mounted Displacement Diffusers
- In-Wall Displacement Diffusers
- Free Standing Displacement Diffusers
- Floor Mounted Displacement Diffusers
- Ceiling Mounted Displacement Diffusers
- Linear Enclosure Diffusers
- Industrial Displacement Diffusers

## SPECIALTY GRILLES, REGISTERS & DIFFUSERS



**Acutherm**  
www.acutherm.com



**Ductsox**  
www.ductsox.com

### VAV Diffusers

- Square VAV Diffusers
- Round VAV Diffusers
- Linear VAV Diffusers

### Pressure Control Products

### Temperature Control Products

### Air Dispersion Products

- Fabric Duct Ventilation
- Fabric Faced Diffusers
- Final Filters



**Air Concepts**  
www.airconceptsinc.com

### Directional Air Distribution Products

- Pankah Diffusers
- Nozzle Diffusers
- Industrial Diffusers

## CRITICAL ENVIRONMENTS



**Price Industries Limited**  
www.priceindustries.com

### Critical Environment Products

- Air Curtain Systems (HORD System)
- Ceiling Systems
- Fan Filter Units
- Horizontal Throw Diffusers
- Laminar Flow Diffusers
- Radial Flow Diffusers
- Specialized Exhaust Diffusers
- Return and Exhaust Grilles

## VENTURI VALVES, HEALTHCARE AND LABORATORY CONTROLS & MONITORS



**PRICE** | CRITICAL CONTROLS

Price Critical Controls  
www.pricecriticalcontrols.com

### Valves

- Venturi Valves – High Turndown Ratio and Mechanical Pressure Independence
- Venturi FX – Measured Airflow and Low Pressure Operation
- Integrated Venturi Valve Assembly Options
  - Performance Guaranteed Venturi with Integrated Silencer Assemblies
  - AHRI 410 Certified Venturi with Hot Water Coil Assemblies
  - UL1995 Certified Venturi with Electric Coil Assemblies

### Healthcare Monitors & Controls

- Room Pressure Monitors
  - Touchscreen Room Pressure Monitor – High Resolution Touchscreen Display
  - Room Pressure Monitor – Digital LCD Display
  - Multi-Variable Monitor – 7 in. High Resolution Touchscreen Displaying up to 8 Rooms on Main Screen
  - All Monitors Have Native BACnet MS/TP Connection
- Room Pressure Controllers
  - Volumetric Offset, Direct Pressure and Dynamic Offset Control
  - Temperature and Humidity Control

### Laboratory Monitors & Controls

- Monitors
  - Fume Hood Monitor
  - Pressure Monitor
- Controllers
  - Fume Hood Controller
  - Lab Space Controller

## SPECIALTY CONTAINMENT & AIR FILTRATION SYSTEMS

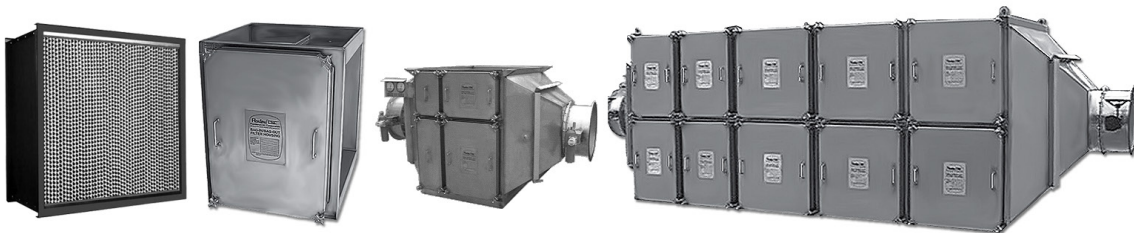

**AAF** | Flanders

AAF Flanders  
www.aafintl.com

### Specialty Containment & Air Filtration Systems

- 95% DOP and HEPA / ULPA Filters
- HEPA Housings and Holding Frames
- CSC Containment Air Filtration Systems (Bag-In / Bag-Out)
- Cleanroom Ceiling Filters and Hoods

## FUME HOODS

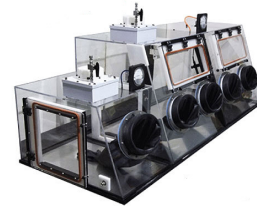

Price Industries Limited  
www.ehpricesales.com



Flow Sciences  
www.flowsciences.com

### Fume Hood Styles Available:

- High Performance Bench Fume Hoods
- Dynamic Bench Fume Hoods
- Dynamic Walk-In Fume Hoods
- General Purpose Chemical Bench Fume Hoods
- Combination Sash Bench Fume Hoods
- Isotope Bench Fume Hoods
- Perchloric Acid Bench Fume Hoods
- General Purpose Walk-In Chemical Fume Hoods
- Base Cabinets Available
- Cupsinks, Fittings, Fixtures, Sinks and Alarms are Available for Most Fume Hood Models

### Containment Enclosure Categories:

- Contained Environment Systems
- Lab Automation / Robotic Equipment
- Pilot Plant / Manufacturing
- Benchtop / Scale Up Containment
- Nanotechnology Systems
- Chemical Fume Hoods
- Chemical Workstations
- Pathology / Anatomy Workstations
- Necropsy Workstations
- Multi-Task Systems
- Glove Box Workstations
- Hybrid Isolators
- Balance Enclosures
- Compounding Hoods

## LABORATORY EXHAUST SYSTEMS



Greenheck  
www.greenheck.com

### Laboratory Exhaust Systems

- High Plume Exhaust Fans
- Available in Single or Multi-Fan Arrangements
- Variable Geometry Nozzle (VGN) Technology
- Energy Recovery Systems (ERS)

## TERMINAL UNITS



**price** | TERMINAL UNITS

Price Industries Limited  
[www.priceindustries.com](http://www.priceindustries.com)

### Terminal Units

- Single Duct Terminal Units
- Bypass Controller Type Terminal Unit
- Control Valves
- Dual Duct Terminal Units
- Fan Powered Terminal Units
- Induction Terminal Units
- Retrofit Terminal Units
- Special Application Terminal Units

## NOISE CONTROL

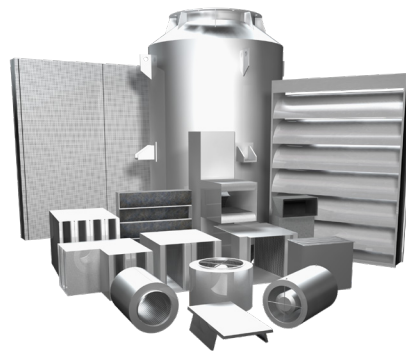

**price** | NOISE CONTROL

Price Industries Limited  
[www.priceindustries.com](http://www.priceindustries.com)

### Silencers

- Commercial and Custom
- Rectangular, Elbow and Circular

- Absorptive, Film-Lined and Packless
- Speech Privacy and Cross-Talk

### Acoustic Products

- Acoustic Enclosures and Barriers
- Acoustical Louvers

## LIFE SAFETY DAMPERS

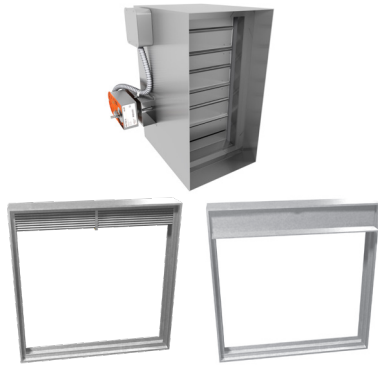

**PRICE** | DAMPERS

**Price Industries Limited**  
www.priceindustries.com

**GREENHECK**  
Building Value in Air.

**Greenheck**  
www.greenheck.com

### Life Safety Dampers

- Fire Dampers
- Combination Fire / Smoke Dampers
- Smoke Dampers
- Ceiling Radiation Dampers
- Combination Fire / Balancing Dampers

### Life Safety Dampers

- Fire Dampers
- Combination Fire / Smoke Dampers
- Smoke Dampers
- Ceiling Radiation Dampers

## NATURAL VENTILATION

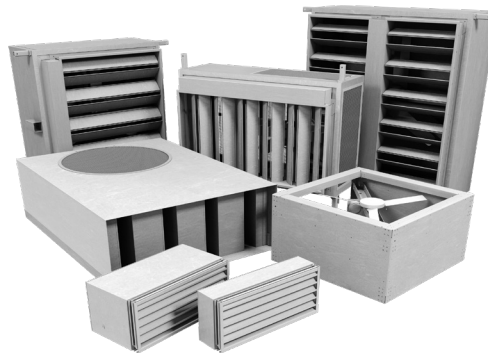

**PRICE** | NATURAL VENTILATION

**Price Industries Limited**  
www.priceindustries.com

### Natural Ventilation

- Wall Unit Air Exchanger
- Roof Mounted Natural Vent
- Facade Mounted Natural Vent
- Rectangular / Square Roof Stack Unit
- Operable Wall Opening



# LOUVERS

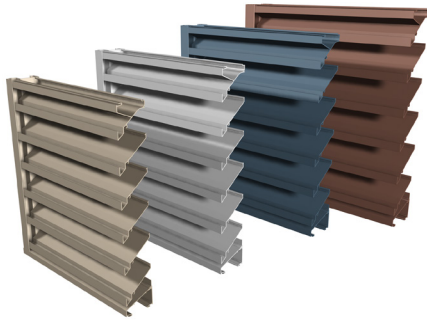

**Price Industries Limited**  
www.priceindustries.com



**Greenheck**  
www.greenheck.com

### Louvers

- Formed Metal Louvers
- Extruded Louvers
- Standard Blade and Chevron Blade Acoustical Louvers
- Extruded Penthouse Louvers
- Formed Metal Penthouse Louvers
- Thinline Wall Application Louvers
- Rain Storm Louvers
- Vision Screens
- Louvered Shapes
- Louvered Doors
- Sunshades
- Architectural Louvers
- Special Louvers as per Request

### Louvers

- Brick Vents
- Stationary Extruded Aluminum Louvers
- Thinline Extruded Louvers
- Sightproof Extruded Louvers
- Adjustable Extruded Louvers
- Combination Extruded Louver / Dampers
- Acoustical Fabricated Louvers
- Wind-Driven Rain Resistant Extruded Louvers
- Sand Louvers
- Penthouse Louvers
- Penthouse Elevator Vent
- Equipment Screens



**Air Louvers Inc.**  
www.airlouvers.com



**TAMCO**  
www.tamco.ca

### Fire Rated Door Louvers

### Louvers

- Extruded Aluminum Louvers
- Intake Louvers with Stormproof Blades Complete with Rain Check
- Exhaust Louvers with Standard Aluminum Blades

## CONTROL, MANUAL & BACKDRAFT DAMPERS

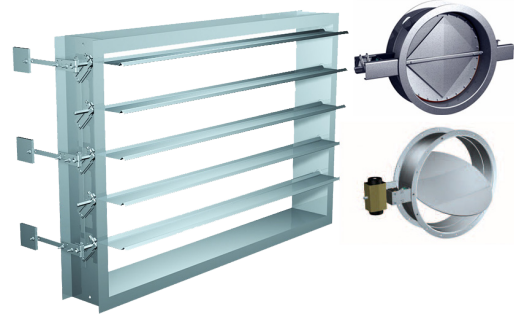
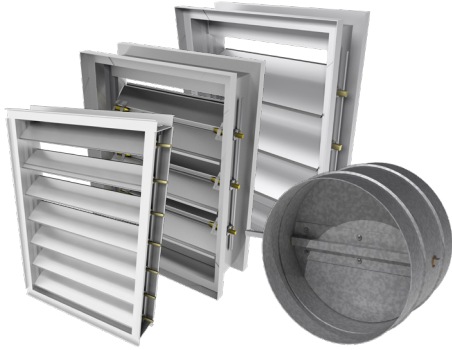

Price Industries Limited  
www.priceindustries.com



Greenheck  
www.greenheck.com

### Dampers

- Backdraft Dampers
- Control and Balancing Dampers

### Actuators

### Access Doors

### Dampers

- Commercial Control Dampers
- Air Measure Products
- Balancing Dampers
- Relief Dampers
- Backdraft Dampers
- Heavy Duty / Industrial Dampers

- Bubble Tight
- Tunnel Transit Dampers
- Marine Dampers

### Access Doors / Pressure Relief Doors

### Actuators



Tamco Innovative Damper Products  
www.tamco.ca



Young Regulator  
www.youngregulator.com

### Dampers

- Aluminum Air-Foil Control Dampers
- High Quality Aluminum Backdraft Dampers
- Thermally Insulated / Thermally Broken Frame Control Dampers

### Dampers

- Bowden Remote Control Dampers and Controllers
- Damper Regulators
- Manual Dampers
- Automatic Changeover Dampers
- Motorized Dampers
- Pressure Relief Dampers

## COMMERCIAL & INDUSTRIAL FANS



**Greenheck**  
www.greenheck.com

### Roof Mounted Fans

- Centrifugal Roof Exhaust Fans
- Centrifugal Upblast Exhaust Fans
- Propeller Tube Axial Fans
- Centrifugal Supply Fans
- Hooded Propeller Exhaust and Supply Fans
- Recirculating Roof Fans
- Roof Curbs

### Gravity Ventilators

### Inline & Ceiling Fans

- Ceiling and Cabinet Fans
- Centrifugal Inline Fans
- Tubular Centrifugal Fans
- Mixed Flow Fans
- Tube Axial Fans
- Vane Axial Medium Pressure Fans
- Vane Axial High Pressure Fans
- Circulator and Mancooler Fans

### Sidewall Exhaust Fans

### Sidewall Propeller Fans

### Utility, Centrifugal & Radial Blowers

- Utility Centrifugal Fans
- Industrial Centrifugal Fans
- Fabricated Pressure Blower
- Industrial Process Fans
- Plug Fans
- Plenum Fans
- Fiberglass Reinforced Plastic (FRP) Fans
- FumeJet Exhaust Systems

### Vari-Green EC Motor Technology

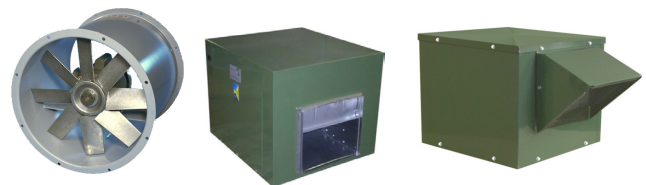
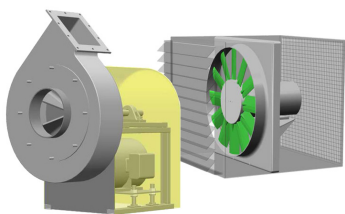

Universal Fan & Blower Ltd.

**Universal Fan & Blower Ltd.**  
www.universalfan.com



**Delhi**  
www.canarm.com

### Industrial & Corrosion Resistant Fans

- Composite FRP / Corrosion Resistant Centrifugal and Axial Fans
- Composite FRP / Corrosion Resistant Wall Exhaust Fans
- Composite FRP / Corrosion Resistant Ductwork

### Commercial Fans

- Duct Blowers
- Roof Exhausters
- Direct Drive Tube Axial
- Belt Drive Tube Axial
- Fresh Air Supply Units
- Utility Blowers
- DWDI-FC Blowers
- DWDI-BIDI Blowers

## COMMERCIAL & INDUSTRIAL FANS

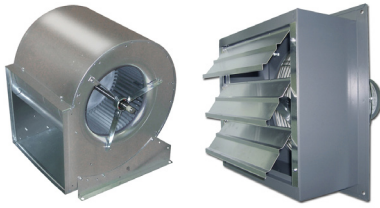

**Canarm**  
www.canarm.com

### Commercial Fans

- Wall Exhaust Fans and Circulating Fans
- Roof Exhausters
- Roof Supply
- Wall Supply / Air Make-Up
- Wall Exhausters
- Inline Duct Fan
- Man Coolers
- Circulating Fans



**Broan**  
www.broan.ca

### Commercial Fans & Range Hoods

- Range Hoods
- Bath and Ventilation Fans
- Air Exchangers



**Panasonic**  
www.panasonic.ca

### Ventilation Fans

- Advanced Ceiling Ventilation Fans
- Fan / Light Combinations
- Through the Wall Ventilation Fans
- Super Quiet Inline Fans



**Reversomatic**  
www.reversomatic.com

### Commercial Fans & Range Hoods

- Discharge Wall Boxes

## COMMERCIAL & INDUSTRIAL FANS



**GNN**  
air

GNN Fans

### Ventilation Fans

- Economical Ceiling Ventilation Fans



**TJERNLUND**  
PRODUCTS, INC.

Tjernlund  
www.tjernlund.com

### Commercial & Industrial Fans

- Sidewall Vent Systems
- In-Line Draft Inducers
- Ventilation Fans
- Duct Booster Fans
- In-Forcer Combustion Air Intake Systems
- In-Forcer Fresh Air Intake Systems
- Santek Electronic Air Cleaners
- Enviro-Tech Head Cooling Fans
- Variable and Fixed Speed Engineer Specified Systems
  - Intelligent Exhaust and Ventilation Systems
  - Constant Pressure Controller
  - Modulating Draft System for Boilers and Water Heaters
  - Modulating Combustion and Make-Up Air Systems
  - Modulating Dryer Venting Systems



**fantech**

Fantech  
www.fantech.net

### Commercial Fans

- Inline Duct Fans
- Bathroom / Kitchen Exhaust Fans
- Round Backdraft Dampers
- Lint Traps
- Heat Recovery Ventilators

## COMMERCIAL & INDUSTRIAL FANS

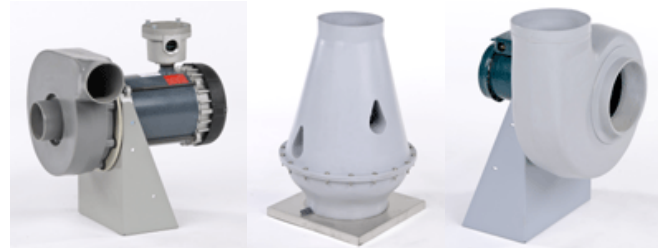

**Plastec**  
www.plastecvent.net

**-fanAm-**

**FANAM Inc.**  
www.fanam.com

### Corrosive Resistant Polypropylene Fans & Blowers

- Centrifugal Fans
- Inline Centrifugal Fans

### Stainless Steel Blowers

### Corrosive Resistant Polypropylene Fans & Blowers

- Centrifugal Blowers
- Roof Exhausters
- Inline Blowers
- Ceiling Exhaust

## KITCHEN VENTILATION SYSTEMS



**Greenheck**  
www.greenheck.com

### Exhaust Hoods

- Type I Wall Canopy Grease Exhaust Hoods
- Type I Single Island Style (V-Bank) Canopy Hoods Grease Exhaust Hood
- Type I Proximity (Backshelf) Grease Exhaust Hood
- Type II Heat and Condensate Hoods
- External Supply Plenums
- **Fire Suppression Systems**
- Residential Range Fire Suppression

### Filter Systems

- Energy Recovery Filter System
- Grease Extraction Filter Systems
- Pollution Control Units

### Utility Distribution Systems

### Controls/Energy Management

- Vari-Flow Air Management System
- Melink Intelli-Hood Controls Available

## COMMERCIAL CEILING DESTRATIFICATION FANS



**BIG ASS FANS**

Big Ass Fans  
[www.bigassfans.com](http://www.bigassfans.com)

### Large Fans For Commercial, Industrial, Governmental & Agricultural Applications

- Summer Cooling
- Winter Destratification / Heat Recirculation
- High Volume, Low Speed Fans
- 6' to 24' in Diameter



**BANVIL 2000**

Banvil 2000 Envirofan  
[www.envirofan.com](http://www.envirofan.com)  
[www.banvil2000.com](http://www.banvil2000.com)

### Ceiling Destratification Fans

### Industrial Ceiling Fans



**CANARM**

Canarm  
[www.canarm.com](http://www.canarm.com)

### Industrial High Performance Ceiling Fans

## HEAT RECOVERY VENTILATORS & ENERGY RECOVERY VENTILATORS

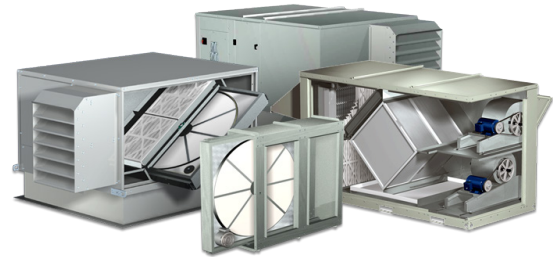

Price Industries Limited  
www.priceindustries.com



Greenheck  
www.greenheck.com

### Regencore Alternating Mass-Exchanger Energy Recovery Units

- With No Pre-Heat Requirements Down to Outdoor Temperatures of -40°C

### Energy Recovery Ventilators

- Preconditioners
- ERV with Cooling and Heating
- Energy Recovery Modules
- Control Options for Energy Recovery Ventilators

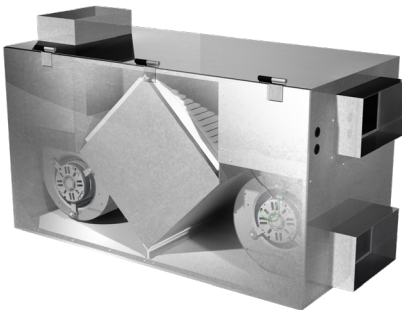

Nu-Air  
www.nu-airventilation.com

### Residential / Commercial HRVs & ERVs

- Air Exchangers, Passive HRVs and Wet Basement Solutions
- Controls and Accessories



# ELECTRIC HEATERS

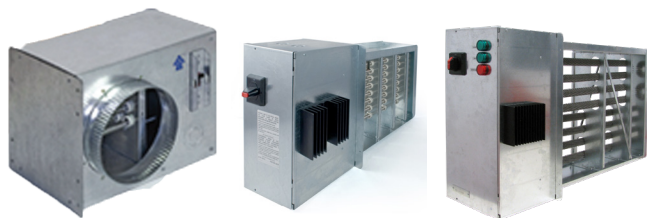

**Nepronic**  
[www.nepronic.com](http://www.nepronic.com)

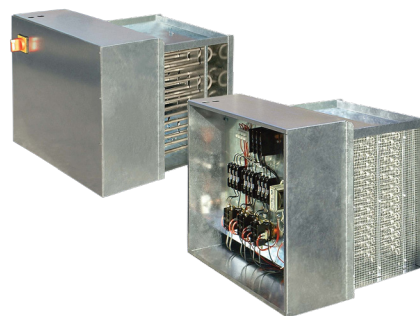

**Price Industries Limited**  
[www.priceindustries.com](http://www.priceindustries.com)

## Electric Duct Heaters

- Open or Tubular Coils

## Electric Duct Heaters

- Open or Tubular Coils



**Ouellet Electric Heating**  
[www.ouellet.com](http://www.ouellet.com)

## Residential / Commercial / Industrial / Architectural Electrical Heating Products

- Baseboard Heaters
- Wall Heaters
- Unit Heaters
- Portable Heaters
- Radiant Heaters
- Draft Barriers
- Cabinet Convector

## AIR FILTRATION PRODUCTS



**AAF Flanders**  
[www.aafintl.com](http://www.aafintl.com)

### Air Filtration Products

- Disposable Air Filters
- Media Pads and Rolls
- Paint Booth Filters
- Odor Control Filters
- Carbon Absorbers
- Pleated Filters
- Medium and High Efficiency Rigid Type Air Filters
- Medium and High Efficiency Extended Surface Type Bag Filters
- ASHRAE Side Access Housings and Holding Frames
- Gaseous / Vapor Phase Side Load and Front Load Housings

## GAS DETECTION



**QEL**  
[www.qelsafety.com](http://www.qelsafety.com)

### Monitoring & Detection Systems

- Indoor Air Quality Monitoring
- Refrigerant Leak Gas Detection Systems
- Gas Detection Systems
- Combustion Analyzers
- Flame Detection



**Honeywell Analytics**  
[www.honeywellanalytics.com](http://www.honeywellanalytics.com)

### Commercial Gas Detection Systems

- Monitors, Controllers and Hand Held Products

## UV PURIFICATION SYSTEMS



**SANUVOX**

**Sanuvox Technologies**  
www.sanuvox.com

### Ultraviolet Air & Object Purification Systems

- Residential, Commercial and Industrial Applications
- In-Duct or Stand Alone Ultraviolet Air Purifiers
- Ultraviolet Object Purifiers for Mold and Bacteria on Evaporator Coils
- Specialty UV Products

## DUST COLLECTION

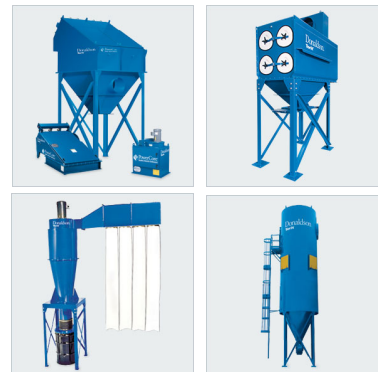
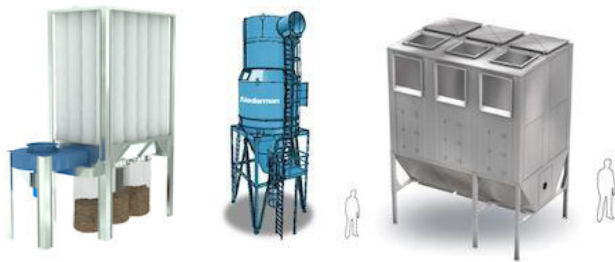

**Nederman**  
IMPROVING YOUR WORKSPACE

**Nederman**  
www.nederman.com

**Donaldson.**  
Filtration Solutions

**Donaldson (Torit)**  
**Filtration Solutions**  
www.donaldson.com

### Dust Collectors

- Baghouse Dust Collectors
- Cartridge Dust Collectors
- Cyclone Dust Collectors

### Industrial Dust, Fume & Mist Collectors

- Cartridge Collectors
- Powercore Collectors
- Baghouse Collectors
- Cyclone Collectors
- Fume Collectors
- Mist Collectors
- Wet Scrubbers
- Downdraft Tables
- Grinding Booths
- Replacement Media

## FUME & VEHICLE EXTRACTION



**Nederman**  
IMPROVING YOUR WORKSPACE

**Nederman**  
www.nederman.com

**Sourcetec**

**Sourcetec**  
www.sourcetecindustries.com

### Fume & Vehicle Extraction

- Fume Extraction Arms and Fans
- Bench Top Flexible Extraction Arms and Fume Cabinets
- Filter Carts and Filter Box Mobile Fume Extractors
- Vehicle Exhaust Fume Extractors and Hose Reels
- Fume Extraction Rail Systems
- Electrostatic and Oil Mist Filters
- Magna Track Fire Station Exhaust Extractors for Rescue Vehicles

### Automotive Exhaust Equipment

### Industrial Cleaning Solutions

### Air Cleaning Systems

## AIR & GAS PURIFICATION



**Unisorb Canada**  
Canada

**Unisorb Canada**  
www.unisorb.ca

### Air & Gas Purification

- Corrosion and Odor Control
- Environmental Emission Control
- Personnel Protection

## AIR CURTAINS



thermoscreens®

**Thermoscreens**  
[www.thermoscreens.ca](http://www.thermoscreens.ca)

**Commercial, Retail & Industrial Air Curtains**

**Biddle Climate Solutions**  
[www.biddle.ca](http://www.biddle.ca)

**Commercial, Retail & Industrial Air Curtains**  
**NOZ Adjustable Nozzle Unit Heater for High Induction**

## VIBRATION ISOLATION



**A VMC Group Company**  
[www.thevmcgroup.com](http://www.thevmcgroup.com)

### Vibration Isolation

- Floor Mounted Isolators
- Bases, Rails and Brackets
- Hangers
- Pad-Type Isolators
- Flexible Connectors
- Piping Specialities
- Seismic Products
- Floating Floor

## INDUSTRIAL HOSE, METAL DUCTING & FABRIC DUCTING

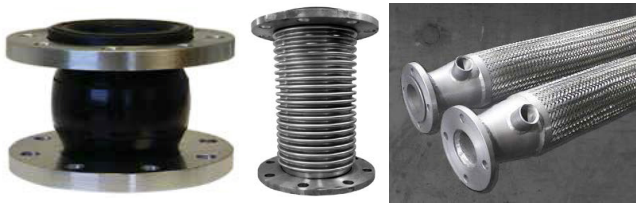

Twin City Hose Inc.  
www.twincityhose.com



Thermafex  
www.thermafex.net

Flexible Metal Hose

Metal Expansion Joints

Rubber / Teflon Expansion Joints

Flexible Hose Products for HVAC

## VFDs & STARTERS



Franklin Control Systems  
www.franklin-controls.com

### HVAC Specialty Products

- Building Automation Starters
- Standard Automation Starters
- Cooling Tower Controls
- Kitchen Hood Controls
- Pump and HVAC Controls

### Industrial Products

- Contactors and Overload Relays
- Manual Motor Starters
- Circuit Breakers
- Starters
- Soft Starters
- Soft Starters with Integrated Bypass

- Programmable Logic Controllers
- Terminal Blocks
- Pilot-Devices
- Enclosures



# CONTROLS



**Price Industries Limited**  
www.priceindustries.com



**Carrier**  
www.carrier.com

**DDC Controls**

- Networked or Stand-Alone Controls
- BACnet Compatible – BTL Certified

**Electronic Stand-Alone Controls**

**Pneumatic Stand-Alone Controls**

**Control Applications:**

- Single Duct Controls
- Fan Powered Controls
- Hydronic Controls
- Bypass Controls
- Underfloor Controls
- Rooftop Controls
- Prodigy Smart Diffusers
- Graphical User Interface

**Fully Integrated Light Commercial & Commercial DDC Systems Including:**

- Operator Interface
- Programmable Controllers
- Zoning Systems
- Network Devices
- Sensors



**Belimo**  
www.belimo.ca

**Electric Damper Actuators**

## PRESSURE GAGES & METERS

---



Dwyer  
[www.dwyer-inst.com](http://www.dwyer-inst.com)

### Pressure Gages & Manometers

- Air Velocity Meters
- Flow Transmitters, Sensors, Meters and Indicators
- Level Indicators, Detectors and Controllers
- Temperature Controllers
- Valves
- Air Quality Instruments
- Hazardous Rated
  - Valves
  - Temperature Transmitters
  - Pressure Switches
  - Flow Products
  - Level Models
  - Pressure Transmitters
- Test Equipment





# MECHANICAL PRODUCTS

## CHILLERS



Carrier  
www.commercial.carrier.com

### Water-Cooled Chillers

- Rotary Hermetic Centrifugal: 200 – 3,000 Tons
- High Efficiency Variable Speed Screw: 175 – 550 Tons
- Rotary Screw: 75 – 400 Tons
- Packaged Scroll: 15 – 71 Tons

### Air-Cooled Chillers

- Packaged Scroll: 10 – 390 Tons
- Packaged Screw: 80 – 500 Tons
- Remote Air-Cooled Scroll: 15 – 71 Tons
- Remote Air-Cooled Screw: 70 – 265 Tons
- High Efficiency Variable Screw: 140 – 500 Tons

### Modular Chillers

- Module Sizes from 15 – 70 Tons
- Up to 8 Modules can be Combined for a Total Capacity of 560 Tons



Aermec  
www.aermec.us

### Water-Cooled Chillers

- Cool Only: 15 – 139 Tons
- Heat Pump: 15 – 139 Tons
- Simultaneous Heat / Cool: 31 – 129 Tons
- Modular: 31 Tons (up to 32 modules)

### Air-Cooled Chillers

- Cool Only: 6.5 – 261 Tons
- Heat Pump: 2 – 261 Tons
- Simultaneous Heat / Cool: 12 – 240 Tons
- Free Cooling: 13 – 236 Tons
- Modular: 29 Tons (up to 9 modules)



Multi-Aqua  
www.multiaqua.com

### Air-Cooled Chillers

- 3, 4, 5 and 10 Ton
- Chilled Water Systems Accessories



## COOLING TOWERS & FLUID COOLERS



**Baltimore Aircoil Company**  
[www.baltimoreaircoil.com](http://www.baltimoreaircoil.com)

**Cooling Towers**  
**Closed Circuit Cooling Towers**  
**Hybrid Closed Circuit Cooling Towers**

**Nexus Modular Hybrid Cooler**  
**Evaporative Condensers**  
**Ice Thermal Storage Units**

**Remote Sump Tanks**  
**Packaged BAC Controls**

## SEPARATORS & PUMPING PACKAGES



**Puroflux**  
[www.puroflux.com](http://www.puroflux.com)

**Filters**  
· Permanent Media Filters  
· Disc Filters

**Separators**  
**Pumping Packages**

## COPPER-SILVER IONIZATION SYSTEMS



Liquitech Environmental Solutions  
www.liquitech.com



H2o Biotech Water Treatment Technologies  
www.h2obiotech.com

**Copper-Silver Ionization Systems for Clean, Safe Water Systems in Hospitals, Hotels & Other Facilities**

**Copper-Silver Ionization  
UV Ozonation**

## SPLIT SYSTEMS

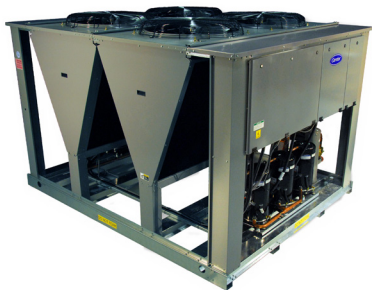

Carrier  
www.commercial.carrier.com



Addison HVAC  
www.addison-hvac.com

### Condensing Units

- Air-Cooled Scroll up to 130 Tons

### Condensers

- Air-Cooled up to 200 Tons

### Split System Air Conditioners

- Custom and Semi-Custom
- Air-Cooled Scroll up to 35 Tons

## PACKAGED INDOOR SYSTEMS

---



**Carrier**  
[www.commercial.carrier.com](http://www.commercial.carrier.com)

### Self-Contained

- Water-Cooled Units: 5 – 100 Tons
- Air-Cooled Units: 3 – 20 Tons
- Remote Air-Cooled Units: 5 – 60 Tons

### PTAC

- Vertical Packaged Terminal Air Conditioners: 9,000 – 24,000 Btuh



**Addison HVAC**  
[www.addison-hvac.com](http://www.addison-hvac.com)

### Water Cooled Indoor Packaged Units

- Water Cooled Units: 3 – 35 Tons (Single Circuit)  
6 – 65 Tons (Dual Circuit)

## DOAS (DEDICATED OUTSIDE AIR SYSTEMS)

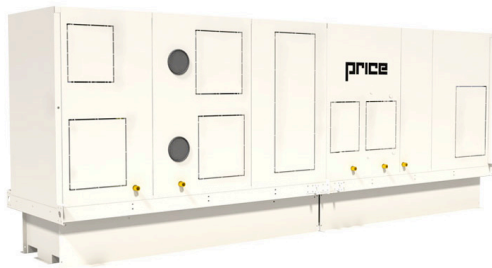

**Price Industries Limited**  
www.priceindustries.com

### Air-Cooled DOAS Units

- 1,000 – 40,000 CFM
- Heating Options: Gas, Electric, Steam and Hydronic
- Cooling Options: Hydronic and DX (Packaged or Split)
- Energy Recovery Options



**Carrier**  
www.commercial.carrier.com

### Air-Cooled DOAS Units

- 700 – 9,000 CFM
- Heating Options: Gas, Electric, Steam and Hydronic
- Energy Recovery Options

### Water Source Heat Pump DOAS Units

- 700 – 9,000 CFM
- Heating Options: Gas, Electric, Steam and Hydronic
- Energy Recovery Options



**Greenheck**  
www.greenheck.com

### Air-Cooled, Water-Cooled & Water Source Heat Pump DOAS Units

- 800 – 13,500 CFM
- Heating Options: Gas, Electric and Hydronic
- Cooling Options: Hydronic and DX (Packaged or Split)
- Energy Recovery Options



**Addison HVAC**  
www.addison-hvac.com

### Air-Cooled, Water-Cooled & Water Source Heat Pump DOAS Units

- 500 – 20,000 CFM
- Heating Options: Gas and Electric

# AIR HANDLERS

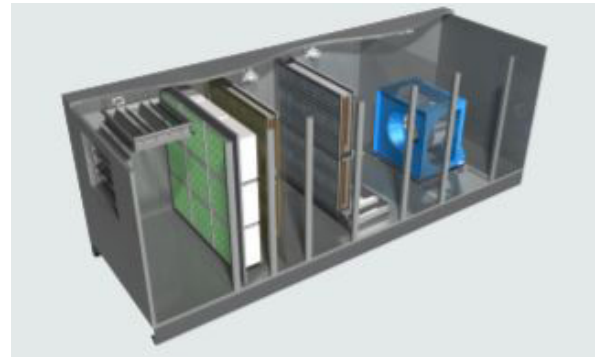

**Carrier**  
www.commercial.carrier.com



**Price Industries Limited**  
www.priceindustries.com

### Air Handlers

- Custom Double Wall Indoor / Outdoor Units: 1,500 – 60,500 CFM
- Compact Single / Double Wall Indoor / Outdoor Units: 400 – 8,500 CFM
- Compact Single / Double Wall Indoor Only Units: 1,800 – 15,000 CFM
- Heating Options: Gas, Electric, Steam and Hydronic
- Cooling Options: Hydronic and DX
- Energy Recovery Options

### Air Handlers

- 500 – 45,000 CFM
- Indoor / Outdoor Construction
- Single / Double Wall Construction
- Heating Options: Gas, Electric, Steam and Hydronic
- Cooling Options: Hydronic and DX (Packaged or Split)
- Energy Recovery
- Packaged Control



**Greenheck**  
www.greenheck.com

### Indoor Air Handlers

- 300 – 4,700 CFM
- Heating Options: Steam and Hydronic (Electric Heat Available on Some Models)
- Cooling Options: Hydronic and DX

## CUSTOM AIR HANDLERS

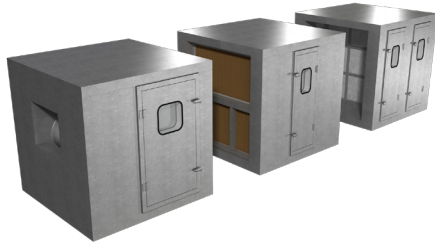

**RACAN®**

Racan / Carrier  
Custom Air Handling Solutions  
[www.racan-carrier.ca](http://www.racan-carrier.ca)

### Custom Air Handlers

- 1,000 – 300,000+ CFM
- Custom Solutions for Retrofit and New Construction
- Central Station Air Handlers
- Air Handlers in Any Configuration
- Knock-Down AHU Construction
- Heating Options: Gas, Electric, Steam and Hydronic
- Cooling Options: Hydronic and DX (Packaged or Split)
- Fan Array
- Integrated Controls



**PRICE** | MECHANICAL

Price Industries Limited  
[www.priceindustries.com](http://www.priceindustries.com)

### Custom Air Handlers

- 500 – 45,000 CFM
- Indoor / Outdoor Construction
- Single / Double Wall Construction
- Heating Options: Gas, Electric, Steam and Hydronic
- Cooling Options: Hydronic and DX (Packaged or Split)
- Energy Recovery
- Packaged Control

## MAKE-UP AIR UNITS



**PRICE** | MECHANICAL

Price Industries Limited  
[www.priceindustries.com](http://www.priceindustries.com)

### Make-Up Air Units

- Direct Fired: 250 – 15,000 MBH
- Indirect Fired Drum and Tube: 250 – 15,000 MBH
- Indirect Fired Convoluted Tube: 75 – 1,400 MBH
- 90% Efficient Indirect Fired: 200 – 1,600 MBH



**GREENHECK**  
Building Value in Air.

Greenheck  
[www.greenheck.com](http://www.greenheck.com)

### Make-Up Air Units

- Commercial and Industrial
- Kitchen Systems
- Direct and Indirect Gas Fired
- Indoor and Outdoor Construction
- Heating Options: Electric, Steam and Hydronic
- Cooling Options: Hydronic and DX (Packaged or Split)

## ROOFTOP UNITS



**Carrier**  
www.commercial.carrier.com

### Rooftop Units (2 – 150 Tons)

- Constant Volume Rooftop Units with Gas or Electric Heat or Cooling Only
- Variable Volume Rooftop Units with Gas or Electric Heat or Cooling Only
- Rooftop Dedicated Outdoor Air Units up to 35 Tons



**Greenheck**  
www.greenheck.com

### Packaged Rooftop Units (5 – 45 Tons)

- Heating Options: Indirect Gas, Electric, Steam and Hydronic
- Cooling Options: Hydronic and DX (Packaged or Split)
- Energy Recovery Options



**Price Industries Limited**  
www.priceindustries.com

### Rooftop Units (Up to 250 Tons)

- Highly Configurable
- Heating Options: Indirect Gas, Electric, Steam and Hydronic
- Cooling Options: Hydronic and DX
- Energy Recovery Options



**Addison HVAC**  
www.addison-hvac.com

### Air Cooled Rooftop Units – Custom & Semi-Custom (3 – 70 Tons)

### Water Cooled Rooftop Units – Custom & Semi-Custom (3 – 70 Tons)



## ROOFTOP UNIT ACCESSORIES

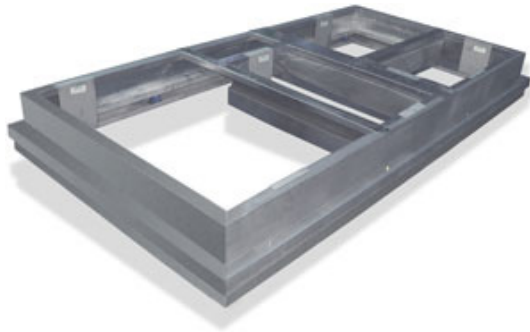

**Spinnaker**  
www.spinnakerindustries.com



**CDI**  
www.cdicurbs.com

### Roof Top Unit Accessories

- Roof Curbs
- Economizers
- Step Down Diffusers

### Air & Water Cooled Self Contained AC Units

### Curb Adapters

### Custom Curbs

## CHILLED BEAMS

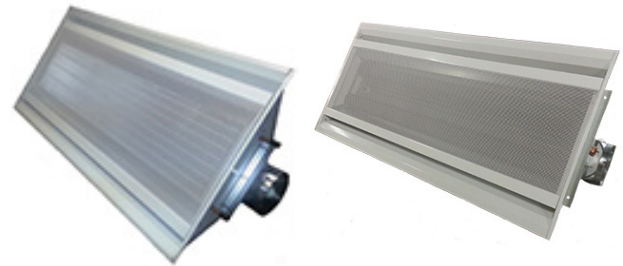

**Price Industries Limited**  
www.priceindustries.com



**Carrier**  
www.commercial.carrier.com

### Chilled Beams

- Linear, Modular, Horizontal, Vertical and Floor-Mounted Active
- Linear Passive
- Passive with Integrated Returns
- Controls and Hose Kits

### Retrofit Perimeter Induction Units

### Active Chilled Beams

### Induction Beams

## INDUCTION UNITS



Carrier  
www.commercial.carrier.com

### Induction Units

- 2-Pipe Bypass Control: 20 – 130 CFM
- 2- or 4-Pipe Water Control: 20 – 130 CFM
- 2-Pipe Bypass Control with Electric Heat: 20 – 130 CFM

## FAN COILS

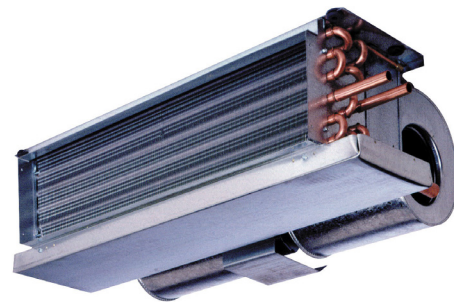
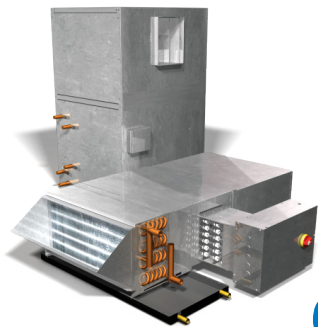

Price Industries Limited  
www.priceindustries.com



Carrier  
www.commercial.carrier.com

### High Performance Fan Coils

- Optional Integrated Silencer
- Standard ECM Motor

### Horizontal Blower Coils

### Vertical Fan Coils

- Concealed and Exposed

### Fan Coils

- Belt-Drive: 600 – 4,000 CFM
- Ducted: 600 – 2,000 CFM
- Horizontal: 600 – 1,200 CFM
- Stack: 300 – 2,000 CFM
- Vertical: 200 – 1,200 CFM
- Hydronic Cassette: 200 – 1,200 CFM

## FAN COILS



**Greenheck**  
www.greenheck.com



**Aermec**  
www.aermec.us

### High Performance Fan Coils

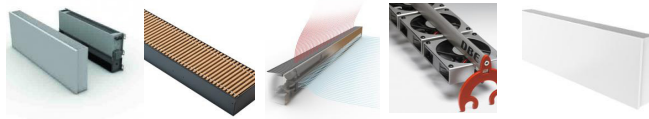

**JAGA**  
www.jaga-usa.com

### Hybrid Heating & Cooling Solution

- Architectural Designer Models and Finishes

### High Efficiency Radiators & Fan Coils

### Slim Fan Coils

### Trench Heaters



**Multi-Aqua**  
www.multiaqua.com

### Fan Coils

- DX and Chilled Water Cooling
- Hot Water and Electric Heating

### Fan Coil Units

- Universal Room Mount: 0.28 – 2.45 Tons
- Ducted Hide-Away: 0.28 – 2.45 Tons
- Highwall: 0.54 – 1.08 Tons
- Cassette: 1.70 – 3.12 Tons
- Multi Zone Distribution Plenum

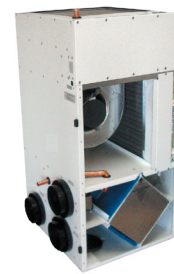

**Nu-Air Ventilation**  
www.nu-airventilation.com

### Enerboss Integrated Air Handlers & Fan Coils with Optional Integral HRV

## COILS



**Greenheck**  
www.greenheck.com

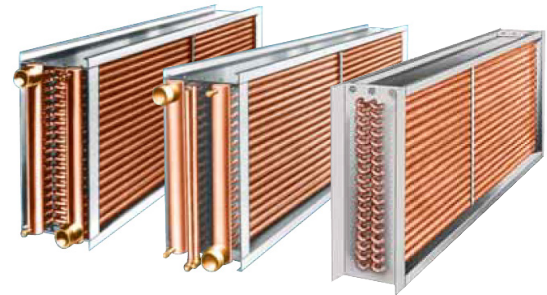

**Aerofin**  
www.aerofin.com

### Coils

- Chilled Water
- Hot Water
- DX Evaporator
- Heat Reclaim
- Condenser
- Standard Steam
- Non-Freeze Steam Distributing
- Booster / Duct Mounted

### Coils

- Finned Tube Heat Exchanger Coils
- Process Gas Coolers / Heaters
- Transformer Oil Coolers
- Fan / Coil Units
- Integral Face and Bypass Coils

## DEHUMIDIFICATION UNITS



**Bry-Air**  
www.bry-air.com

**Ultra-Low Dewpoint Dehumidification (300 – 30,000 CFM)**

**Add-On Dehumidification Section for Custom or Commercial AHU (300 – 30,000 CFM)**

**Standard Desiccant Dehumidifiers (100 – 1,200 CFM)**

## HYDRONIC HEAT & UNIT HEATERS



**Vulcan Radiator**  
www.vulcanrad.com



**Price Industries Limited**  
www.ehpricesales.com

### Commercial Hydronic Heating

- Commercial Wall-Fin Radiation
- Light Commercial Wall-Fin Radiation
- Cabinet Unit Heaters
- Convectors
- Horizontal and Vertical Unit Heaters
- Panel Radiators
- Custom Enclosure
- Security Enclosure

### Radiant Heating & Cooling Systems

- Linear Ceiling Panels
- Modular Ceiling Panels
- Security Ceiling Panels
- Custom Ceiling Panels

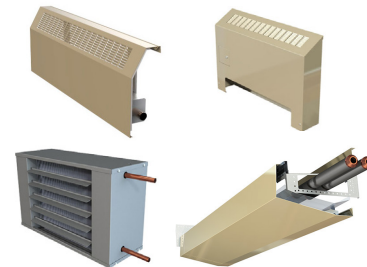

**Sterling HVAC Products**  
www.sterlinghvac.com



**Sigma**  
www.sigmaproducts.com

### Commercial Gas Heating

- Gas Fired Unit Heaters
- Gas Fired Duct Furnaces

### Commercial Hydronic Heating

- Hydronic Unit Heaters
- Cabinet Unit Heaters
- Convectors
- Wall-Fin

### Commercial Hydronic Heating

- Wall-Fin Radiation
- Convectors
- Cabinet Unit Heaters
- Unit Heaters
- Valence Units
- Panel Radiators

## HEAT PUMPS



**Florida Heat Pumps**  
[www.bosch-climate.us](http://www.bosch-climate.us)



**Carrier**  
[www.commercial.carrier.com](http://www.commercial.carrier.com)

### Heat Pumps

- Split: ½ – 6 Tons
- Water-to-Water: 2 – 35 Tons
- Water-to-Air: ½ – 60 Tons
- Geothermal: ½ – 60 Tons
- Roof Top: 4 – 30 Tons
- Console: ¾ – 1 ½ Tons

### Water Source Heat Pumps

- Horizontal: ½ – 20 Tons
- Vertical: ½ – 30 Tons
- Console: ¾ – 1 ½ Tons
- Water-to-Water: 2 – 35 Tons



**Aermec**  
[www.aermec.us](http://www.aermec.us)



**Addison HVAC**  
[www.addison-hvac.com](http://www.addison-hvac.com)

### Air-to-Water Heat Pumps

- Outdoor Mounted Heat Pump: 2 – 261 Tons
- Indoor Mounted Heat Pump: 15 – 90 Tons
- Simultaneous Heat / Cool: 12 – 240 Tons

### Water-to-Water Heat Pumps

- Heat Pump: 15 – 139 Tons
- Simultaneous Heat / Cool: 31 – 129 Tons

### Water-to-Water Heat Pumps (3 – 35 Tons)

## BOILERS



**Patterson-Kelley**  
Harsco

**Patterson-Kelley**  
www.harscopk.com

### Boilers

- Condensing Boilers
- Non-Condensing Boilers
- Hybrid Systems
- Integrated Controls
- Direct Water Heaters
- Indirect Water Heaters
- Pool Heaters
- Replacement Bundles

## CHIMNEYS



**ICC Chimney**  
www.icc-chimney.com

### Chimneys

- Condensing Vent Sizes 5" Through 24"
- Single Wall, Double Wall and Insulated
- UL Listed for Category I, II, III, IV Gas Fired Appliances
- AL29-4C or 444 Stainless Steel Construction
- Canadian Manufactured

## HUMIDIFIERS



**Neptronic**  
www.neptronic.com

### Humidifiers

- Electric
- Gas Fired
- Steam-to-Steam
- Direct Steam
- High Pressure Atomizing
- Evaporative
- Steam Distribution Systems
- Humidity Controls

## FLUID & HEAT RECOVERY SYSTEMS



**Envirosep Fluid & Heat Recovery Systems**  
www.envirosep.com

### Custom Packages

- Hot Water Systems
- Condensate Handling Systems
- Domestic Water Booster Pump Packages
- Flash Recovery and Blowdown Systems
- Chilled Water Packaged Pumping Systems
- Heat Transfer Systems
- Steam Pressure Reducing Stations
- Steam Trap Stations
- Process Cooling Systems
- Industrial Process Solutions
- Wastewater Heat Recovery
- Reverse Osmosis and Fluid Recovery Systems
- Deareator and Boiler Feedwater / Condensate Handling
- Industrial Controllers
- Industrial Control Panels



## FLUID CONTROL

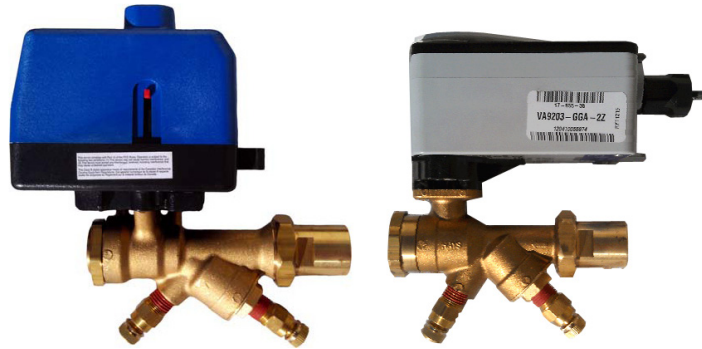

Hays Fluid Control  
[www.haysfluidcontrols.com](http://www.haysfluidcontrols.com)

### Flow Controls

- Manual and Automatic

### Hose Kits & Piping Packages

- Fully Assembled and Tested
- Solenoid Valves

**Custom-Designed Fluid Control Products for a Wide Range of Unique Applications**

## RADIANT HEATERS



Schwank  
[www.schwankgroup.com](http://www.schwankgroup.com)

### Infrared Heaters

- Gas Fired and Electric Infrared Radiant Heaters

- Tube and Luminous Style Radiant Heaters

- Patio Heaters

## CRITICAL ENVIRONMENT COOLING SOLUTIONS



**ClimateWorx**  
www.climateworxinternational.com

### Cooling Systems

- Vertical Floor Mount Systems: 2 – 50 Tons
- Wall Mount Systems: 1.5 – 2.5 Tons
- Ceiling Mount Systems: 1 – 5 Tons
- High Density In-Row Cooling: 3 – 16 Tons
- Microprocessor Controller M52

## COMPRESSED AIR & AUXILIARIES



**Curtis Air Compressors**  
www.fscurtis.com



**Pneumatech-Conservair**  
www.pneumatech.com

### Compressors

- Rotary Screw and Reciprocating
- Oil-Free Screw and Oil-Less Reciprocating
- Climate Control

### Refrigerated Dryers

- Desiccant and Blower Purge Dryers

### Vacuum Pumps

#### Accessories

- Air Line Filters and Accessories
- Flow Controllers
- Air Accessories

### Controllers

- Intermediate Pressure Control
- Flow Controllers / Demand Expanders
- Refrigerated Air Dryers
- Desiccant Air Dryers
- Compressed Air / Gas Filters
- Condensate Management

## COMPRESSED AIR PIPING



**Legris Transair**  
www.parkertransair.com

### Compressed Air Piping

- Quick Connection Fluid and Air Piping Systems
- Compressed Air / Vacuum / Fluids / Liquids / Inert Gases
- Stainless Steel for Liquid Applications
- Push to Connect Fittings
- Aircraft Aluminum Pipe with Composite Fittings
- Clean Air Quality
- Corrosion Free

## VFDs & STARTERS



**Franklin Control Systems**  
www.franklin-controls.com

### HVAC Specialty Products

- Building Automation Starters
- Standard Automation Starters
- Cooling Tower Controls
- Kitchen Hood Controls
- Pump and HVAC Controls

### Industrial Products

- Contactors and Overload Relays
- Manual Motor Starters
- Circuit Breakers
- Starters
- Soft Starters
- Soft Starters with Integrated Bypass

- Programmable Logic Controllers
- Terminal Blocks
- Pilot-Devices
- Enclosures



# CONTROLS



**PRICE** | CONTROLS

**Price Industries Limited**  
www.priceindustries.com



**Carrier**

**Carrier**  
www.carrier.com

### DDC Controls

- Networked or Stand-Alone Controls
- BACnet Compatible – BTL Certified

### Electronic Stand-Alone Controls

### Pneumatic Stand-Alone Controls

### Control Applications

- Single Duct Controls
- Fan Powered Controls
- Hydronic Controls
- Bypass Controls
- Underfloor Controls
- Rooftop Controls
- Prodigy Smart Diffusers
- Graphical User Interface

### Fully Integrated Light Commercial & Commercial DDC Systems

- Operator Interface
- Programmable Controllers
- Zoning Systems
- Network Devices
- Sensors



**BELIMO**

**Belimo**  
www.belimo.ca



**Honeywell**  
ANALYTICS

**Honeywell Analytics**  
www.honeywellanalytics.com

### Control Valves

- Electronic Control Valves
- Zone Control Valves
- Globe Valves
- Butterfly Valves

### Actuators

### Monitors, Controllers & Hand Held Products

## PRESSURE GAGES & METERS

---



Dwyer  
www.dwyer-inst.com

### Pressure Gages & Manometers

- Air Velocity Meters
- Flow Transmitters, Sensors, Meters and Indicators
- Level Indicators, Detectors and Controllers
- Temperature Controllers
- Valves
- Air Quality Instruments
- Hazardous Rated
  - Valves
  - Temperature Transmitters
  - Pressure Switches
  - Flow Products
  - Level Models
  - Pressure Transmitters
- Test Equipment





# E.H. PRICE THUNDER BAY

660 Balmoral Street – Unit C, Thunder Bay, ON P7C 5G9

Ph: 807.622.3311 Fax: 807.622.0744

thunderbay@ehpricesales.com

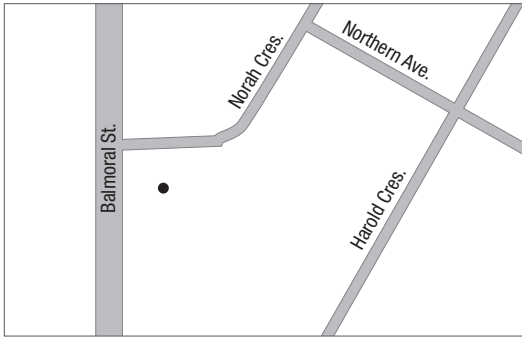

## Paul Schimnowski

Regional Vice President

Ph: 204.982.2224

pschimnowski@ehpricesales.com

## AIR DISTRIBUTION, INDUSTRIAL AND MECHANICAL DIVISIONS

### Tony Baldassi

Branch Manager

Ph: 807.622.3311

tbaldassi@ehpricesales.com

### Andrew Olinski

Sales Representative

Ph: 807.622.3311

aolinski@ehpricesales.com

## SERVICE DIVISION

### Justin Mitchell

Service Technician

Ph: 204.982.4215

jmitchell@ehpricesales.com

## LOCAL DELIVERY AVAILABLE

Specifications are subject to change without notice. Consult your E.H. Price sales representative for current specifications or more detailed information.

**Warranty:** The Company warrants and guarantees that all goods within this brochure that have been manufactured by the Company have been manufactured in accordance with the specifications published herein and will be free from defects in material and workmanship for a period of twelve (12) months from the Bill of Lading issued by the Company. The Company will replace defective product at its option, but will not be responsible for labor or material charges in replacing product or consequential damages. Any installation not conforming with the Company's specifications, manuals, bulletins or instructions or any misuse or any modification not authorized by the Company voids this warranty. This warranty is in lieu of all Provincial, State, and Federal statutory warranties and the conditions herein are in substitution and replacement of which warranties, statutory or otherwise.



Air Distribution Division



Industrial Division



Mechanical Division

First in Quality, First in Service  
[www.ehpricethunderbay.com](http://www.ehpricethunderbay.com)

**e.h.price**